

## DESCRIPTION : ELECTROPNEUMATIC HORN

DESCRIZIONE : AVVISATORE ELETTROPNEUMATICO

# M4/TA3

### Main specifications and performances / Principali caratteristiche

<b>Nominal voltage</b> / Voltaggio nominale	<b>12</b>	Vdc
<b>Voltage range</b> / Voltaggio di utilizzo	<b>11,5-13,8</b>	Vdc
<b>Current consumption</b> / Assorbimento	<b>20</b>	A
<b>Produced pressure</b> / Pressione prodotta	<b>&gt; 0,45</b>	bar
<b>Sound pressure level</b> / Livello sonoro	<b>116 (2m)</b>	dB(A)
<b>Frequency 'L'</b> / Frequenza tono basso	<b>655</b>	Hz
<b>Frequency 'M'</b> / Frequenza tono alto	<b>768</b>	Hz
<b>Frequency 'H'</b> / Frequenza tono alto	<b>828</b>	Hz
<b>Operating temperature</b> / Temp. di utilizzo	<b>-30° to +80°</b>	°C
<b>Storage temperature</b> / Temp. stoccaggio	<b>-30° to +80°</b>	°C
<b>Corrosion resistance</b> / Resist. alla corrosione	<b>&gt; 480 (salt spray test)</b>	Hours
<b>Operating relative humidity</b> / Umidità di esercizio	<b>30 to 80</b>	%
<b>Durability</b> (1 sec ON, 4 sec OFF) / Durata	<b>&gt;50 000</b>	Cycles
<b>Continuous blowing</b>	<b>&gt; 2,5</b>	min
<b>Electrical insulation</b> / Isolamento elettrico	<b>500</b>	Vdc
<b>Vibration</b> (30 min, 3 axis) / Vibrazioni	<b>1</b>	g
<b>Weight</b> / Peso	<b>810</b>	gr
<b>Main Materials</b> / Principali materiali	ABS, Steel, Aluminium	
<b>Main applications</b> / Principali applicazioni	Cars, Trucks	

### Dimensions (mm) / Dimensioni (mm)

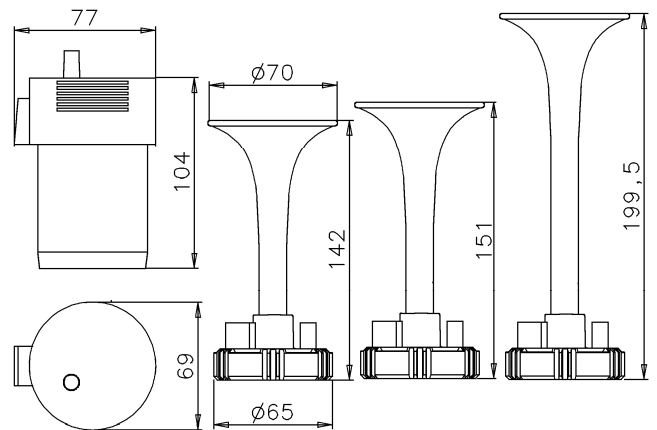

### Available Electrical Connection / Connessioni elettriche disponibili

Double Pole Terminal 6,3x0,8 mm / 2 Morsetti



### Pneumatic connection / Connessione pneumatica

Trumpets/compressor : Plastic tube L=667 / Tubo di plastica L=667mm

### Conformity to Standards of / Conformità agli Standards

<b>PRODUCT</b> PRODOTTO	✓ CEE 70/388
	✓ R. 28 ECE/ONU
	✓ CEE 95/54
<b>MANUFACTURING</b> PRODUZIONE	✓ ISO/TS 16949
	✓ ISO 9001
	✓ ISO 14001
	✓ QS 9000

### Other specifications / Ulteriori specifiche

**Mechanical connection** : flat and rigid surface facing the bracket edge

Montaggio meccanico : fissare la staffa ad una superficie piana e rigida

**Horn's Protection**: choose an installation area protected from direct water and mud splash

Protezione : installare al riparo da spruzzi d'acqua e fango

**Packaging**: Clam shell

Imballo : Blister

**Master carton**: 10 pieces

Imballo multiplo : cartone da 10 pezzi

### Product and packaging / Prodotto e confezione

