

DESCRIPTION : AIR POWERED HORN

DESCRIZIONE : AVVISATORE PNEUMATICO

FULTONE-T

Main specifications and performances / Principali caratteristiche

Sound pressure level / Livello sonoro	117 (2m)	dB(A)
Frequency 'L' / Frequenza tono basso	260	Hz
Frequency 'H' / Frequenza tono alto	300	Hz
Working pressure / Pressione di esercizio	500 - 1200	kPa
Air consumption / Consumo d'aria	0,9	l/sec
Operating temperature / Temp. di utilizzo	-30 °C to +80	°C
Storage temperature / Temp. stoccaggio	-30 °C to +80	°C
Corrosion resistance / Resist. alla corrosione	> 600 (salt spray test)	Hours
Operating relative humidity / Umidità di esercizio	30 to 80	%
Durability (1 sec ON, 4 sec OFF) / Durata	>50 000	Cycles
Continuos blowing	60	min
Vibration (30 min, 3 axis) / Vibrazioni	1	g
Weight (each) / Peso (cad.)	900	gr
Main Materials / Principali materiali	ABS	
Main applications / Principali applicazioni	Trucks	

Dimensions (mm) / Dimensioni (mm)

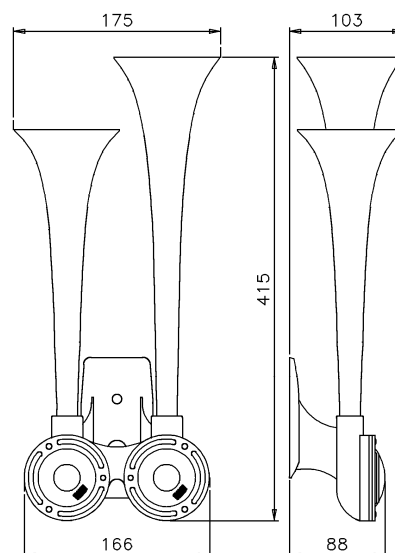

Pneumatic connection / Connessione pneumatica

G 1/8"

Other specifications / Ulteriori specifiche

Mechanical connection : flat and rigid surface facing the bracket edge

Montaggio meccanico : fissare la staffa ad una superficie piana e rigida

Horn's Protection: choose an installation area protected from direct water and mud splash

Protezione : installare al riparo da spruzzi d'acqua e fango

Packaging: Color box 465 x 180 x h100 mm

Imballo : Scatola cartone 465x180xh100 mm

Master carton: 6 pieces

Imballo multiplo : cartone da 6 pezzi

Conformity to Standards of / Conformità agli Standards

PRODUCT ✓ CEE 70/388
PRODOTTO ✓ R. 28 ECE/ONU

MANUFACTURING ✓ ISO/TS 16949
PRODUZIONE ✓ ISO 9001
 ✓ ISO 14001
 ✓ QS 9000

